



# Oztech

# Lite

# Oztech Lite Overview

Oztech Lite is a compact 3m x 3m automated retractable shelter purpose built for New Zealand conditions. Outdoor living made simple – a ready to install, non-custom solution that provides reliable shelter and flexible all-season use without unnecessary extras.

## Key Features

- Remote controlled retractable roof system
- Instant sunlight, shade or sky
- Fast lead times
- Easier installation
- All-weather protection. High wind zone
- Robust construction
- Dulux Duralloy powder-coated frame finish
- Easily compatible with side screens

**3m** Fixed Width Coverage      **3m** Fixed Projection Coverage

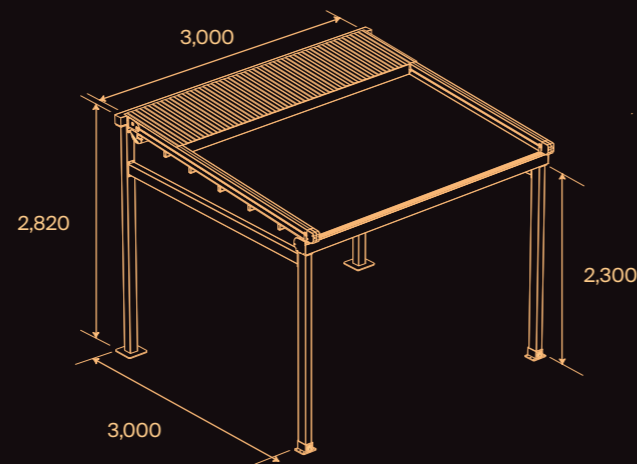

“We’ve added a whole new space for the family to enjoy all year”

## Smart Outdoor Living, Made Simple

Rafter Dimensions	80 x 120
Top Hood End Line	10 - 25
Post → Rafter Cap End	103 - 120
Rafter End → Edge	33
Post → Gutter Front Face	22
Post → End of Post Base	18
Frame Colour Options	Satin Black or Appliance White
Fabric Type / Colour	White Bochini

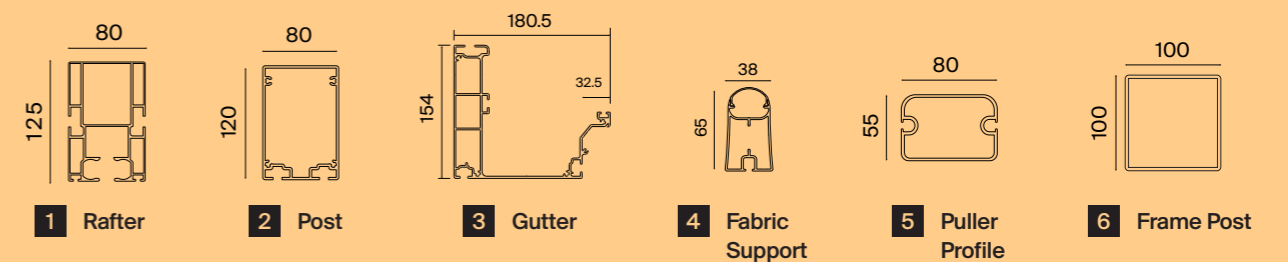
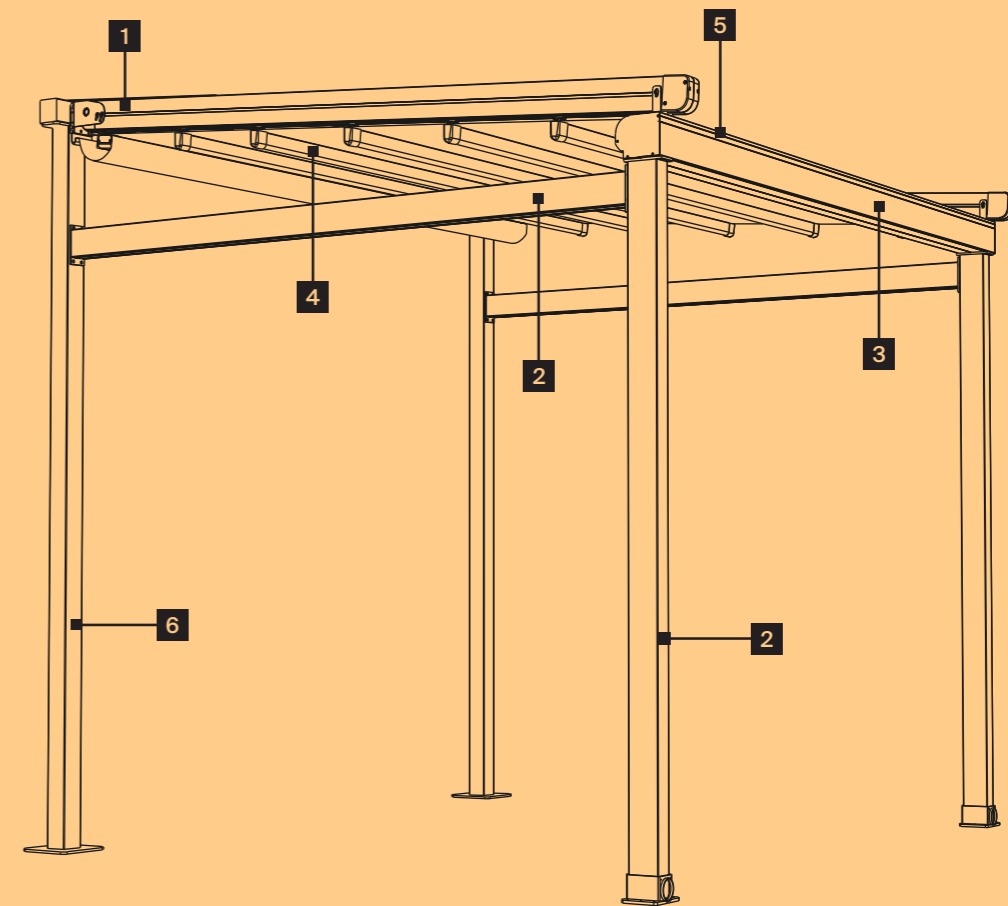

# Contact Us

Experience the perfect balance of sunlight & shade with the Oztech Lite System.

Have any questions?  
Contact us using the details below.

Oztech New Zealand  
0800 656 000  
info@oztech.co.nz  
oztech.co.nz

